



## DOVER SERIES

### Adjustable 180 Degree Glass-to-Glass Hinge

52054-ADJ

**PRODUCT NAME:** DOVER - Adjustable 180 Degree Glass-to-Glass Hinge

**PRODUCT CODE:** 52054-ADJ

**MATERIAL:** All-brass construction

**KEY FEATURES:** Heavy Duty Shower Hinge.  
Glass to Glass.  
Square Edge.  
Adjustable

**FINISHES:**

- Polished Chrome (99)
- Brushed Nickel (81)
- Matte Black (48)
- Brushed Brass (78)

**SPECIAL FINISHES AVAILABLE:** Please see our website for full list samples

**WARRANTY:**

Lifetime Limited (Residential Use)  
Three Years (Commercial Use)

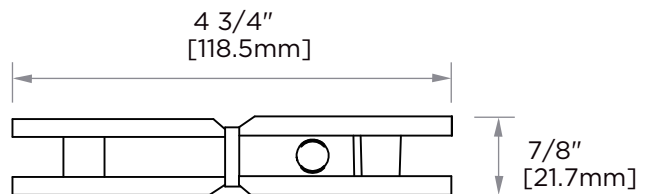
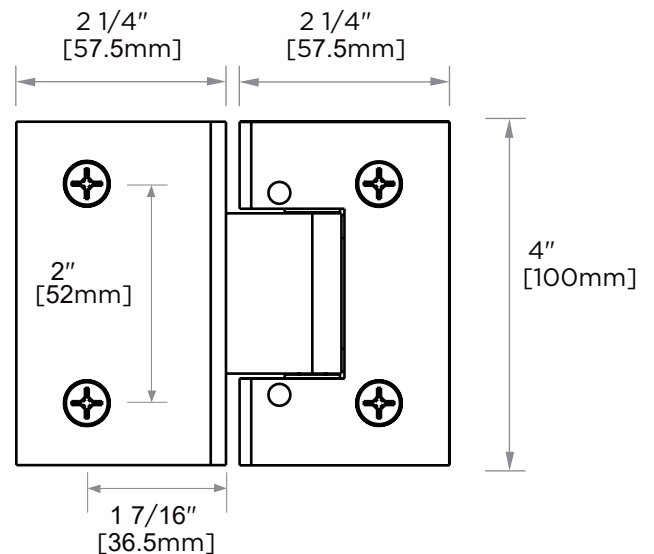

NOTE: Dimensions and specifications are subject to change without notice.

### 180° GLASS-to-GLASS HEAVY DUTY HINGE

**SPECIFICATIONS**

For 10mm (3/8") and 12mm (1/2") glass  
 -use 2 hinges, having a maximum weight of 110 lbs (50kg), and a width of 36"(914mm).  
 -use 3 hinges, having a maximum weight of 140 lbs (63kg), and a width of 36" (914mm).

**ASSEMBLY**

for 3/8"(10mm) glass use thick rubber on each side  
 for 1/2"(12mm) glass use thin rubber on each side

**CAUTION**

For public safety, we recommend only using tempered or safety glass.  
 (But verify with local building codes.)  
 DO NOT USE POWER TOOLS FOR MOUNTING THESE HINGES

**CLEANING**

See reverse side for instructions

* Maximum Door Capacities	3/8" (10mm) Glass Weight	Width	1/2" (12mm) Glass Weight	Width
Using 2 Hinges	110 lbs.(50kg)	36"(914mm)	110 lbs.(50kg)	36"(914mm)
Using 3 Hinges	140 lbs.(63kg)	36"(914mm)	140 lbs.(63kg)	36"(914mm)

\*NOTE: Do not exceed either maximum weight or width when choosing proper quantity of hinges.

### 180° GLASS-to-GLASS HEAVY DUTY HINGE

Rectangular Cut-out Option

IMPORTANT:  
Project measurements from the edge of the glass

"Mouse-Ear" Cut-out Option

NOTE: Dimensions and specifications are subject to change without notice.