

BERLIN COLLECTION
SHELF W/ DOUBLE
TOILET PAPER
HOLDER
232159-2

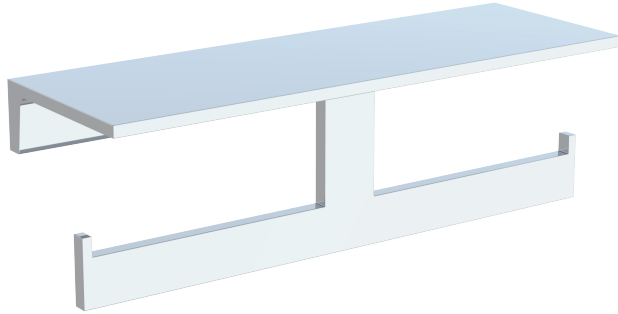

PRODUCT NAME: SHELF W/ DOUBLE TOILET PAPER HOLDER

PRODUCT CODE: 232159-2

MATERIAL: All-brass construction

KEY FEATURES: Contemporary design with solid bold rectangular geometry.

STOCKED FINISHES:

- Polished Chrome (99)
- Brushed Nickel (81)
- Polished Nickel (68)
- Matte Black (48)

SPECIAL FINISHES AVAILABLE: Please see our website for the full list

WARRANTY:
Lifetime Limited (Residential Use)
One Year (Commercial Use)

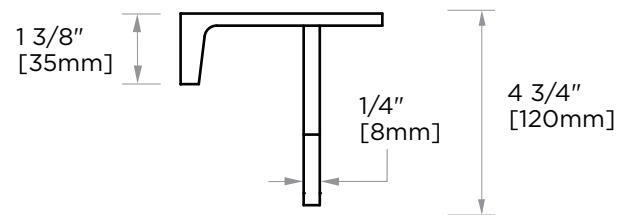
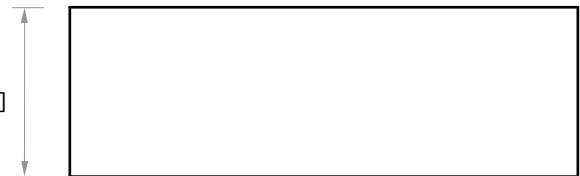
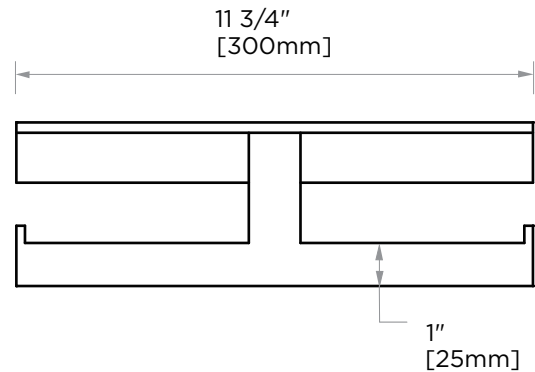

NOTE: Dimensions and specifications are subject to change without notice.